

Essay on Magnetic-Wind Mills

Part II : Staying Power from Spacetime

J.L. Duarte
 Eindhoven - The Netherlands
magnetogenesis@proton.me

Abstract—One of the missing links in support of the allegation that devices with only magnets seemingly generate useful energy "out of thin air" could be *Spacetime twisting*. This discussion paper applies the concept to self-rotating machines previously claimed in patents.

I. INTRODUCTION

Classical Electromagnetism (EM) precludes the possibility of building a device that generates sustained mechanical power based solely on the attraction/repulsion of permanent magnets (PMs) [1]. However, in the periphery of Science many inventions concerning allegedly self-running magnet machines have been reported for decades. There are so many of them that specific PCT identification labels¹ are warranted. By contrast, in the eyes of mainstream Physics such inventions are dismissed as symptoms of a fascinating human obsession with *Perpetua Mobilia*².

Nevertheless, a newly developed extension of Einstein's general relativity theory, called ECE (Einstein-Cartan-Evans) theory [2], provides a foundation for understanding magnet-only prime-movers.

In the next sections three self-rotating magnet motor candidates are analyzed in the context of ECE theory. Conditions for induction of resonance in ambient spacetime are shown, which, according to [2], could explain the transfer of energy from spacetime itself to the device, thus creating a steady flow of mechanical power.

II. SELF-RUNNING MACHINES

The first device is the subject of a patent filed in Brazil in 1989 [5], so it can be considered disclosed prior-art in present time. The inventor proposes a base magnetic assembly as shown in Fig. 1, and claims that when stacking and interleaving a few sets around a rotatable central shaft (label 2 in Fig. 1) the device exhibits self-running behavior and becomes a prime-mover.

In Fig. 1, the PMs on the rotor and stator are located in sockets (3 and 4, respectively). The stator sockets are in line with the rotor ones, both with the same angular displacement (angle α) referenced to the rotor radius.

The displaced angle α is intended to soften sharp transitions from repulsive to attractive magnetic forces while spinning.

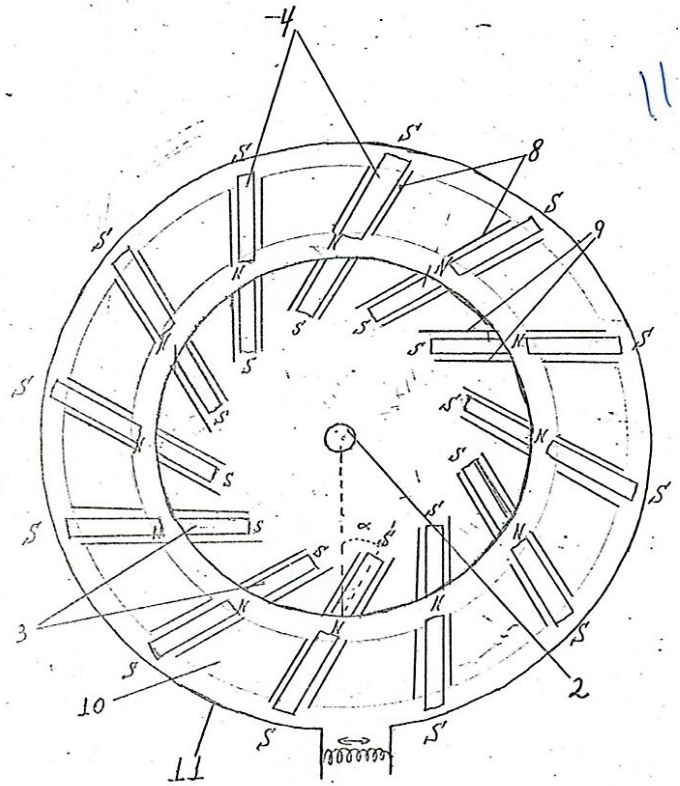

Fig. 1: Original drawings of a magnet-only base assembly as given in [5], consisting of rotor and stator with PMs embedded in sockets. By stacking and interleaving such base sets around a shaft, the resulting device would behave as an autonomous prime-mover.

Moreover, for further improvement of motor performance, it is also advised to include socket linings of ferromagnetic material (8 and 9), such that the PMs are partially screened and, therefore, the resulting magnetic field becomes more longitudinally focused.

It is stated in [5] that the gap depth between stator and rotor magnets allows steering the rotation speed. For this purpose, and to avoid expulsion during operation, the stator PMs are retained in open sockets (10 in Fig. 1) by means of an adjustable exterior metal belt (label 11). As such, the stator magnets are not firmly attached, and consequently they will somehow vibrate mechanically during operation (a feature not

¹H02K 53/00, H02N 11/00
²Counting from 2015 onwards, PatBase shows 3100 patent families of genuine alleged perpetual motion machines.

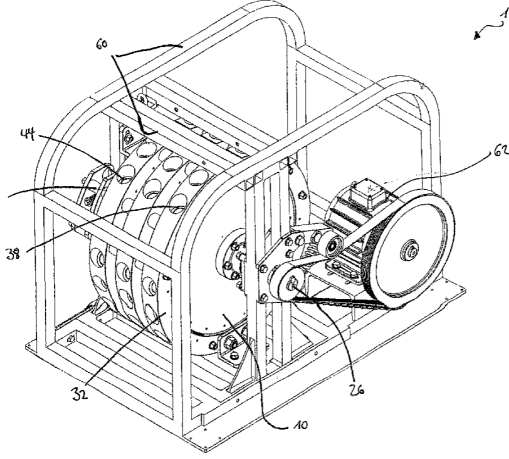

Fig. 2: Magnet-only machine as claimed in [6], consisting of PMs embedded in sockets and fastened by locking pins.

evidenced in the patent). In particular, these vibrations must be explicitly taken into account with respect to ECE theory, because magnetic harmonic oscillations, even of quite limited magnitude, are the key to generating resonance in spacetime, as explained in the next section.

Unfortunately, no verifiable record has been found whether an engine prototype based on [5] has been effectively demonstrated to work. Still, it is an intriguing situation when compared to another patent filed in Germany in 2004 [6].

Fig. 2 shows the self-running motor in [6], which is strikingly similar to the one in [5], although [5] is not mentioned in the prior-art search report of [6]. The subtle difference in [6] is that, in order to hold the PMs in place and prevent them from driven out of the sockets during operation, the rotor and stator magnets contain a locking pin through transversal holes. So, as with [5], the PMs are not sturdily fastened. With an inferior fit between locking pins and transversal holes, (tiny) mechanical vibrations inevitably occur during rotation.

Perhaps the use of tighter locking pins is the reason why the inventor in [6] was unable to reproduce the operation of the device in later implementations, despite some successful public demonstrations with earlier prototype versions (so goes the well-known story about the *Perendev project*). Being unaware of the essential need for small mechanical vibrations (nothing about this is mentioned in [6]), it could be that in later prototypes the mounting of PMs in sockets with pins had been "much improved", nullifying the vibrations (with tragic legal consequences).

Interestingly, in 2020 an anonymous inventor from The Netherlands posted a series of videos on YouTube [7] showing a self-running magnet motor in full operation. This device can be seen as a very simplified implementation of the ideas in [5] and [6]. It consists of an assembly set with four PMs on the rotor and only one on the stator. The required magnetic oscillations are realized with an uncomplicated synchronizing mechanical artifact when stator and rotor magnets pass each other during rotation. The autonomous and steady rotation is

recorded in the movies, while the device parts are transparently dissected to show their internal contents.

Continuing along the path of high expectations initiated in Part I of this essay [8], a qualitative analysis of the possible origin of the mean torque that would lead to auto-rotation in the above inventions is conducted further in the framework of ECE theory.

III. RESONANCE IN SPACETIME

Stacking identical base assemblies as outlined in Fig. 1 around a common shaft, while interleaving the base assemblies with a constant angular offset, produces an overall cylindrically shaped package. The resulting magnetic field in the region between rotor and stator will present circularity. To a first approximation, the radial part of the magnetic flux density, \vec{B} , can be described as a circularly polarized plane wave given by

$$\vec{B} = B [\cos(\kappa z - \omega t), \sin(\kappa z - \omega t), 0] \begin{bmatrix} \hat{e}_x \\ \hat{e}_y \\ \hat{e}_z \end{bmatrix} \quad (1)$$

where B (in Tesla) has constant magnitude and $\{\hat{e}_x, \hat{e}_y, \hat{e}_z\}$ are orthonormal Cartesian vectors, with \hat{e}_z aligned with the longitudinal shaft in the cylindrical assembly. In (1) the value of wave-number κ is found from the dimensions of the base assembly, together with the amount of stacked base sets in conjunction with the applied interleaving angle, and ω denotes the angular frequency of the rotating shaft.

It is usual practice in classical EM to describe the magnetic field \vec{B} with the aid of a vector potential \vec{A} as

$$\vec{B} = \vec{\nabla} \times \vec{A} \quad \text{and} \quad \vec{\nabla} \cdot \vec{A} = 0 \quad (2)$$

Accordingly, it is found from (1) and (2) that

$$\vec{\nabla} \times \vec{A} = -\kappa \vec{A} \quad (3)$$

That is to say, the potential \vec{A} in (3) has characteristics of a Beltrami flow³ (and consequently also \vec{B} in (1)).

The back-and-forth movement of the stator PMs due to the approach and subsequent depart of the spinning rotor magnets produces an additional, pulsed component in the magnetic flux density in the region between rotor and stator. Using the same orthonormal basis in (1), the first-harmonic approximation of the magnetic pulses in the radial direction is obtained with

$$\vec{B}_0 = B_0 \cos(\omega t + \varphi) [\cos(\kappa_0 z), \sin(\kappa_0 z), 0] \begin{bmatrix} \hat{e}_x \\ \hat{e}_y \\ \hat{e}_z \end{bmatrix} \quad (4)$$

where the magnitude B_0 (in Tesla) and the phase shift φ are functions of the displaced angle α . Furthermore, since the stator parts follow the same stacking and interleaving pattern as the rotor parts, it results equal values for the spatial frequencies κ and κ_0 . Otherwise stated, by construction

$$\kappa_0 = \kappa \quad (5)$$

It should be noted that the harmonic oscillations of \vec{B}_0 are perfectly synchronized with the angular frequency ω of \vec{B} in

³Flows in which the velocity vector \vec{v} and the vorticity vector $\vec{\nabla} \times \vec{v}$ are parallel to each other.

(1). The reason for this is that the rotor and stator magnets attract/repel each other at the same rate given by the angular frequency ω of the rotor.

Similarly to (2), a vector potential \vec{A}_0 associated with \vec{B}_0 is found from (4) as

$$\vec{B}_0 = \vec{\nabla} \times \vec{A}_0 = -\kappa_0 \vec{A}_0 \quad (6)$$

ECE theory deals with magnetogenesis, and states that magnetic field may be generated from torsion in spacetime [2]. In this section, we track [3] and [4].

Magnetic flux density as created from spacetime is describe in its simplest form by

$$\vec{B}_S = \vec{\nabla} \times \vec{A}_S - \vec{\omega} \times \vec{A}_S \quad (7)$$

where $\vec{\omega}$ is a spin connection vector to twisting in spacetime. The subscript S in (7) is introduced to emphasize quantities generated by the spacetime, not by the magnetic assembly itself. In case of a potential \vec{A}_S consisting of circular plane waves, $\vec{\omega}$ gets a special form leading to

$$\vec{\omega} \times \vec{A}_S = -\kappa \vec{A}_S \quad (8)$$

and (7) is found to become

$$\vec{B}_S = \vec{\nabla} \times \vec{A}_S + \kappa \vec{A}_S \quad (9)$$

The spatial frequency κ in (9) is a quantity imposed by the magnetic geometry of the assembly, as before, and, to stress it again, the quantities \vec{A}_S and \vec{B}_S are properties of spacetime itself where the assembly is located.

Under equilibrium conditions, the spacetime around the magnetic assembly produces no magnetic flux, hence $\vec{B}_S = 0$. In this case, given (9),

$$\begin{aligned} \vec{\nabla} \times \vec{B}_S &= 0 \\ \vec{\nabla} \times (\vec{\nabla} \times \vec{A}_S) + \vec{\nabla} \times (\kappa \vec{A}_S) &= 0 \\ \vec{\nabla}(\vec{\nabla} \cdot \vec{A}_S) - \nabla^2 \vec{A}_S - \kappa^2 \vec{A}_S &= 0 \end{aligned} \quad (10)$$

Since for circular plane waves $\vec{\nabla} \cdot \vec{A}_S = 0$, it results from (10) that

$$(\nabla^2 + \kappa^2) \vec{A}_S = 0 \quad (11)$$

Overall, (11) is a Helmholtz equation that defines equilibrium conditions in the spacetime around the magnetic assembly, when there is no Cartan torsion and therefore no external magnetic field generation. Consequently, there is no spacetime related torque to rotate the magnetic assembly.

Torque can be create by disturbing the Beltrami flow, which means the equilibrium at zero in (11) must no longer be fulfilled. In this context, the ECE theory forecasts that a periodic imbalance may disturb the structure of the ambient spacetime [4]. Under disturbances, (11) is then transformed to an undamped resonator with a driving term.

In this report, we assume further that the oscillations introduced in spacetime by the pulsed potential \vec{A}_0 given in (6) modifies (11) by adding a right-hand term as

$$(\nabla^2 + \kappa^2) \vec{A}_S = \gamma \vec{A}_0 \quad (12)$$

for some value of γ .

From the general form in (12), the Cartesian components of \vec{A}_S , say $\{A_{Sx}, A_{Sy}, A_{Sz}\}$, are readily found. For instance, after manipulations with (4) and (6), it follows from (12) that

$$\frac{\partial^2 A_{Sx}}{\partial z^2} + \kappa^2 A_{Sx} = \gamma A_0 \cos(\omega t + \varphi) \cos(\kappa_0 z) \quad (13)$$

for which the solution is found to become

$$A_{Sx} = \frac{\gamma}{(\kappa^2 - \kappa_0^2)} A_0 \cos(\omega t + \varphi) \cos(\kappa_0 z) \quad (14)$$

On account of (5), the resonance introduced by disturbance \vec{A}_0 will induce the vector potential component A_{Sx} to grow towards infinity, even for quite small values of γ in (14). As a result, an external magnetic field, \vec{B}_S , is created from spacetime around the magnetic assembly, which gives rise to a torque on the PM magnetic moments \vec{m} as

$$\vec{T}_S = \vec{m} \times \vec{B}_S, \quad (15)$$

with \vec{T}_S high enough to make the shaft rotate.

Finally, the energy flow required to keep rotation going presumably comes from the resonance interactions with the chaotic and abundant vacuum energy, ubiquitously available in spacetime [2].

IV. CONCLUSION

This discussion paper makes a link between (unintended) PM mechanical vibrations and the power output of patented devices. ECE's theory explicitly states that useful energy can be obtained from spacetime via this framework. The theory points to the opening of an energy gateway, and could provide a basis for development and engineering of self-running machines. *Is it too good to be true?* Further experiments with previously disclosed inventions may lead to a clear answer to this research question.

REFERENCES

- [1] E.P. Furlani, *Permanent magnet and Electromechanical Devices: materials, analysis and applications*. Academic Press, London, 6th ed., 2001
- [2] H. Eckardt, *Einstein-Cartan-Evans Unified Field Theory - The Geometrical Basis of Physics* (textbook), 2022, Paper 438, UFT section www.aias.us
- [3] M.W. Evans and H. Eckardt, *Spin connection resonance in magnetic motors*, Physica B 400, 2007, pp. 175-179
- [4] H. Eckardt, *How do space energy devices work?*, 2007, <http://aias.us/documents/miscellaneous/SpaceEnergy.pdf>
- [5] M.C. Malafaia, *Motor magnetico*, PI 8900294 A, Brazilian patent office INPI, Aug 1990, (in Portuguese)
- [6] M. Brady, *Permanent magnet machine*, WO 2006/045333 A1
- [7] Anonymous, *Self running magnetic motor*, (posted in Oct 2020), <https://www.youtube.com/watch?v=bNPNEgb1EEI>
- [8] J.L. Duarte, *Essay on magnetic-wind mills - Part I analysis and design*, TU Eindhoven Research Report, Feb 2019, <https://doi.org/10.6100/94FC4756-AC0A-4A9C-A1DD-58530E694BB8>